

# Chap. 4 General Features of Detectors

Primary Ionization is created by the interaction of the primary radiation in the bulk material of the ‘detector’ – then what?

Rate	Technique	Device	Energy Proportionality?	Temporal Information?	Position Information?
Low	Collect ions	Ion Chamber	Can be Excellent	Poor	Average
	Multiply & Collect ions	Proportional Chamber	Very good	Average	Good
	Convert into photons	Scintillation Detector	Acceptable	Good to Excellent	Poor
	Create discharge	Geiger-Mueller Ctr. PPAC Spark chamber	No	Good to Excellent	Excellent
High	Collect current	Ion Chamber	Radiation Field	None	None

# General Features of Detectors – High Rates

Ion Chamber: the individual pulses are summed in a system that has a long time-constant.

$$I = r (E / w) q_e = r Q$$

where  $I$  is the current,

$r$  is the rate of the incident radiation,

$E$  is the energy deposited in the sensitive volume  $\sim 10$ 's keV

$w$  is the “effective work function” for bulk material  $\sim$  few tens of eV

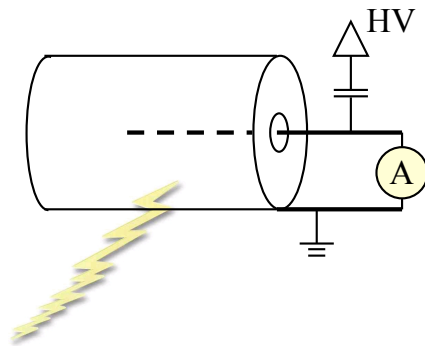

For example: 0.01 MeV deposited in an air-filled ion chamber  
 $w = 34$  eV/IP for *fast electrons* [Table 5.1 in text]

whereas the ionization potentials for  $O_2 = 12.1$  eV,  $N_2 = 15.6$  eV

*Values from NIST*

$$N_{IP} = E / w = 10^4 \text{ eV} / (34 \text{ eV} / \text{IP})$$

$$N_{IP} = 3 \times 10^2 \rightarrow \sigma_{N_{IP}} / N_{IP} = \sqrt{N_{IP}} / N_{IP} = 6 \times 10^{-2}$$

for a statistical distribution

$$I = r (E / w) q_e$$

$$I = r (3 \times 10^2 \text{ IP}) 2 \times 1.602 \times 10^{-19} \text{ coul} / \text{IP}$$

$$I = r (1 \times 10^{-16}) \text{ coul}$$

# General Features of Detectors – Single Pulse

Single Pulse: the electronics have to be sensitive enough to process the signal and not lose it in the noise (low noise electronic amplifiers, physical amplification of primary ionization occurs in proportional chambers & other devices).

- Circuit is fast enough to follow the collection of the ionization and one has a current pulse.
- Circuit is slower than the collection time and one gets a voltage pulse.

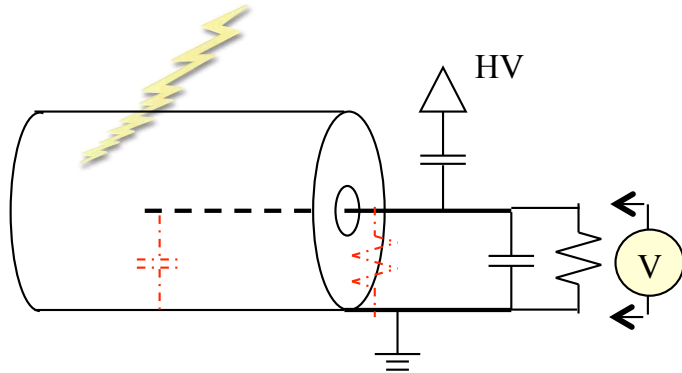

Characteristic time,  $\tau = RC$

Typical  $R \sim 50 \Omega$

Typical  $\tau = 1 \text{ ns} \rightarrow C \sim 20 \text{ pF}$

Note:  $V_{\text{max}} \sim Q/C$

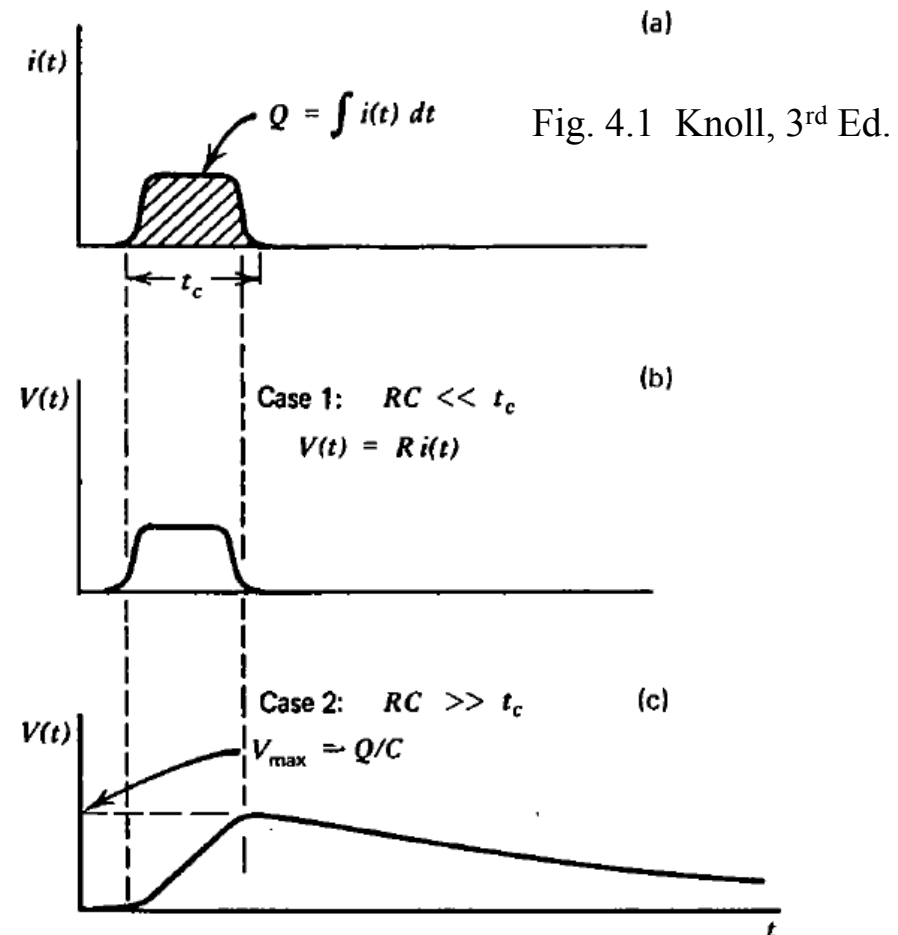

# General Features of Detectors – Pulse Heights

Pulse Height Distribution: the detector usually produces a distribution of pulses even from a monoenergetic source due to incomplete charge collection, geometrical path-length differences, or sometimes various interactions of the radiation in the bulk material.

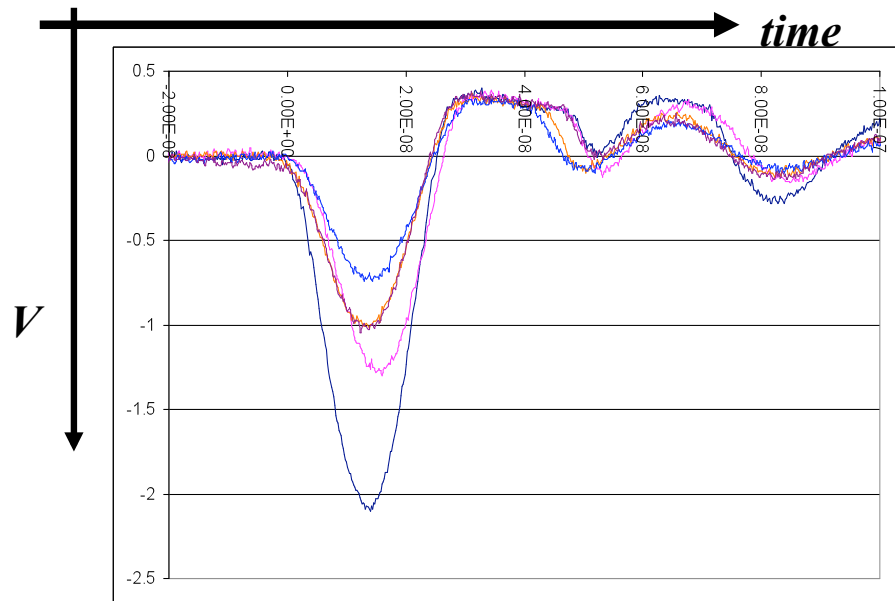

*Number  
Of Pulses  
Per 0.25 V*

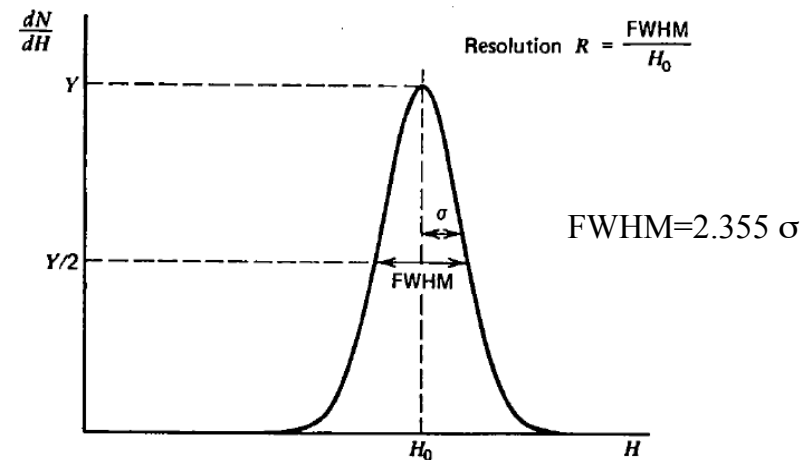
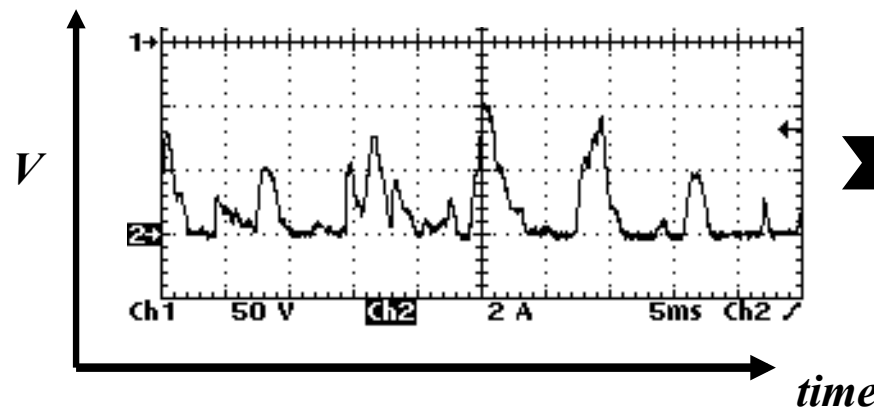
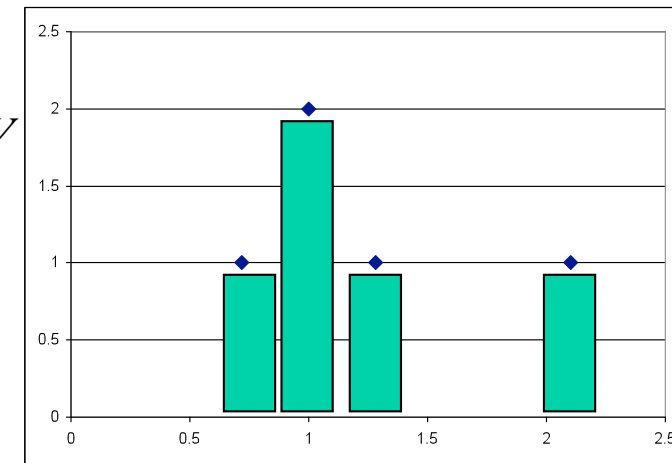

# General Features of Detectors – Resolution

Pulse Height Resolution: a detector that is used to determine an energy signal must produce a signal that is proportional to the initial number of ion pairs. If the number of pairs is random then:

$$R_{Poisson} = \frac{FWHM}{\bar{x}} = \frac{\kappa(2.355\sigma)}{\kappa N_{IP}} = \frac{(2.355\sqrt{N_{IP}})}{N_{IP}} = \frac{2.355}{\sqrt{N_{IP}}}$$

$$N_{IP} = \frac{E}{w} \quad \therefore \quad R_{Poisson} \propto \frac{1}{\sqrt{E}} \quad \left\{ 2.355 = 2\sqrt{2\ln 2} \right\}$$

Recall that the total number of IP's is not truly random, e.g. if “w” has a small range of values (very pure or single crystal materials), the energy deposited by a stopping particle will be an exact number. Thus, the resolution of the system can be “better” than statistical.  $s^2 = \sigma^2 F$  where is the *Fano factor*.

*U.Fano, Phys. Rev. 72 (1947) 26*

$$R_{observed} = \frac{FWHM_e}{\bar{x}_e} = \frac{(2.355\sqrt{N_{IP}F})}{N_{IP}} = 2.355\sqrt{\frac{F}{N_{IP}}}$$

Silicon, CdTe	F ~ 0.1 to 0.15
Pure gas	F ~ 0.2 to 0.4
Scintillator	F ~ 1

A system with a *linear gain*  $\kappa$  should have a resolution that is proportional to  $1/\sqrt{E}$

Pulse Height Resolution: The Resolution will be made up from several parts added together in quadrature. For example,

$$R_{observed}^2 = R_{source\ lineshape}^2 + R_{intrinsic}^2 + R_{electronic\ noise}^2 + \dots$$

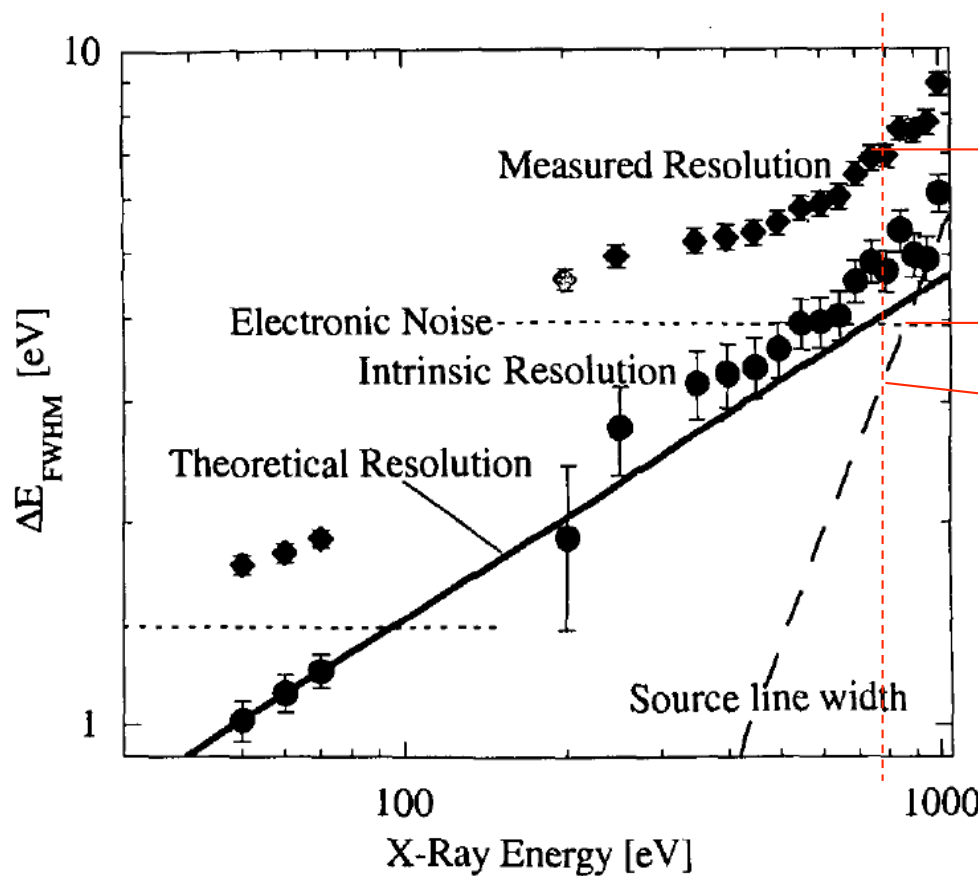

$$R_{obs}^2 = (7)^2$$

$$R_{noise}^2 = (4)^2$$

$$R_{lineshape}^2 = (3.3)^2$$

Making  $R_{intrinsic}^2 \sim (5)^2$  at 800eV

$R_{intrinsic}^2$  viz.  $R_{theory}^2 \sim F(w/E)$

Results for a Superconducting Tunnel-Junction Device by Friedrich, et al. *IEEE Trans. App.Supercon.* 9 (1999) 3330

# General Features of Detectors – Efficiency

Efficiency: detection efficiency (a dimensionless quantity) is usually broken into three terms times an angular distribution function:

$$N_{\text{obs}} = N_{\text{absolute}} \epsilon_{\text{total}} = N_{\text{absolute}} W(\Theta, \Phi) \epsilon_{\text{geo}} \epsilon_{\text{intrinsic}} \epsilon_{\text{electronic}}$$

- the first three terms depend on the detector configuration and are *static*
- the electronic term is *rate dependent* and is due to the ‘dead-time’ of the system

$$\epsilon_{\text{geo}} = \frac{\Omega}{4\pi} \leftrightarrow \Omega = 4\pi \epsilon_{\text{geo}}$$

E.g., thin circular detector at a distance ‘d’

$$\epsilon_{\text{geo}} = \frac{1}{2} \left( 1 - \frac{d}{\sqrt{d^2 + a^2}} \right)$$

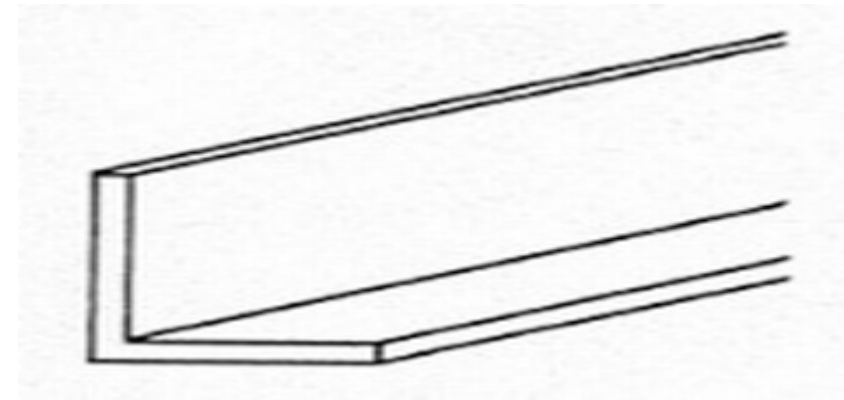
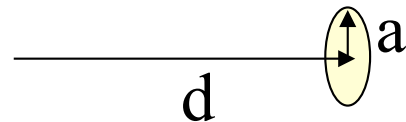

d=1	$\Omega = 4\pi \epsilon_{\text{geo}}$	$\Omega \sim \pi a^2/d^2$
a= 0.01	0.000314 sr	0.000314 sr
a=0.05	0.00784	0.00785
a=0.1	0.0312	0.0314
a=0.5	0.663	0.785
a=1	1.84	3.14

# General Features of Detectors – Dead Time – 1

The efficiency of a system to measure and record pulses depends on the time taken up by all components of the signal processing. There are two classes of systems, those that require a fixed recovery time and those that don't.

## Dead Time Models:

a) Paralyzable – detector system is affected by the radiation even if the signal is not processed. (a “slow” detector or electronics)

b) Nonparalyzable – fixed dead-time

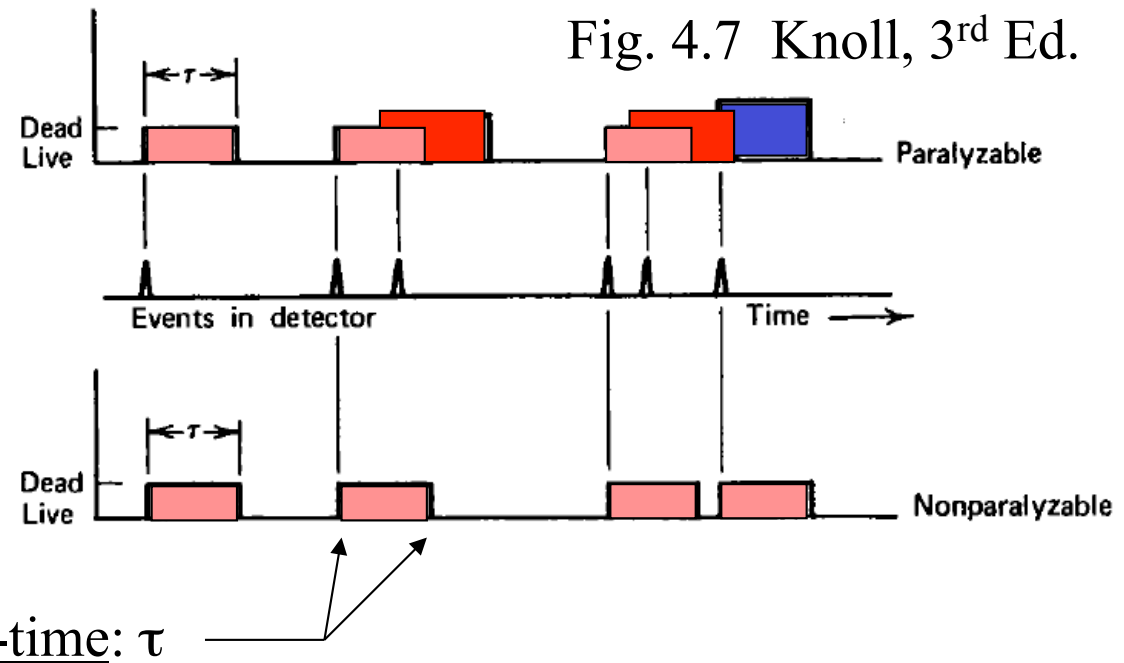

True rate:  $r$  or  $n$  (in text)

Obs. rate:  $r_{obs}$  or  $m$  (in text)

Dead-time:  $\tau$

Paralyzable – if the time gap between events is larger than  $\tau$  then the event will be recorded. The observed rate is equal to the rate at which time intervals occur that exceed  $\tau$ .

$$I_1(t)dt = r e^{-rt} dt \rightarrow P(\tau) = \int_{\tau}^{\infty} r e^{-rt} dt = e^{-r\tau}$$

$$r_{obs} = r e^{-r\tau} \quad [m = ne^{-n\tau}]$$



# General Features of Detectors – Dead Time – 2

## Dead Time Models:

b) Nonparalyzable – detector system is not effected if the signal is not processed.

(a “fast” detector)

$$\text{Loss rate} = r - r_{\text{obs}} \quad \text{or } n - m \text{ (in text)}$$

$$\text{Fraction dead} = r_{\text{obs}} \tau \quad \text{or } m \tau$$

$$[ \text{Loss rate} = r (r_{\text{obs}} \tau) \quad \text{or } n (m \tau) ]$$

$$\text{Fraction live} = (1 - r_{\text{obs}} \tau) \text{ or } (1 - m \tau)$$

$$r_{\text{obs}} = r (1 - r_{\text{obs}} \tau) \rightarrow r = r_{\text{obs}} / (1 - r_{\text{obs}} \tau)$$

Decay example:

$$A = A_0 e^{-\lambda t}$$

$$A_0 = 10^6 \quad \tau = 10^{-5}$$

$$A_0 = 10^3 \quad \tau = 10^{-5}$$

Deadtime in a non-paralyzable leads to a depression of the decay curve of a source at short times (high rates).

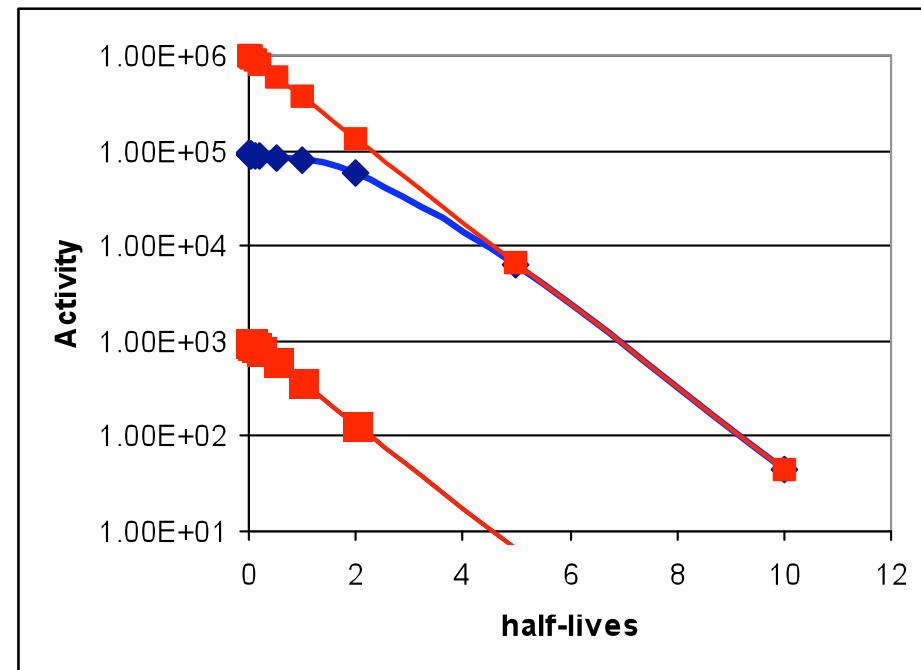

## Dead Time Models:

a) Paralyzable –  $r_{\text{obs}} = r e^{-r\tau}$

b) Nonparalyzable –  $r = r_{\text{obs}} / (1 - r_{\text{obs}} \tau)$

Fig. 4.8 Knoll, 3<sup>rd</sup> Ed.

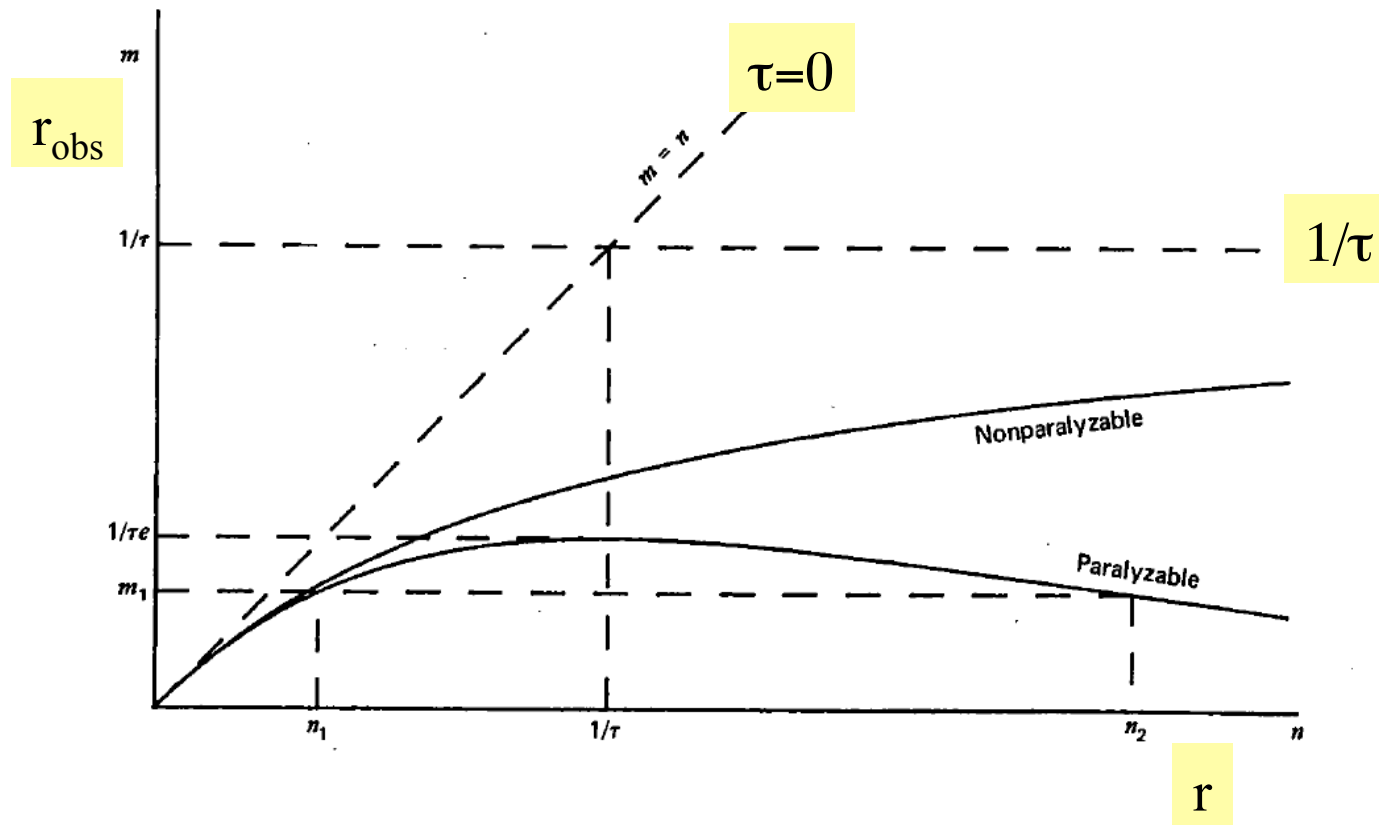

# General Features of Det. – Instantaneous Rate

## Accelerated Beams:

- a) Electrostatic machines – true “DC” , Interval Distribution of times
- b) Rf-based machines – quantized arrival times & duty factor
  - a) Cyclotrons – approximately continuous current above microlevel (ten’s ns)  
duty factor = 1
  - b) Linacs – rf-micropulses (few ns) inside a macropulse (few ms)  
duty factor = macropulse time in ms / 1000
  - a) Synchrotrons – rf-micropulses (few ns) inside a macro-spill (few s)  
duty factor = 1 during pulse , = 0 outside pulse

E.g., NSCL cyclotrons:  $f \sim 20$  MHz and beam arrives in a bucket  $< 2$ ns

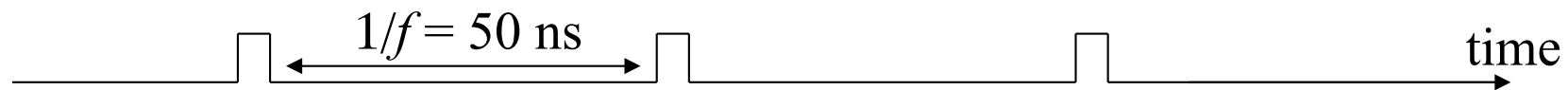

$$f = 20 \text{ MHz} \rightarrow 2 \times 10^7 \text{ buckets / s}$$

$$I = 16 \text{ pA} \rightarrow \Phi = \frac{16 \times 10^{-9} \text{ A}}{1.602 \times 10^{-19} \text{ coul / part}} = 10^{11} \text{ part / s}$$

$$\Phi' = \frac{10^{11} \text{ part / s}}{2 \times 10^7 \text{ buckets / s}} = 5 \times 10^3 \text{ part / bucket}$$

E.g., reaction with a typical Be target in the A1900

$$R'_{\text{reaction}} = N_0 \Phi' \sigma = \left( \frac{500 \text{ mg / cm}^2 * N_A / \text{mol}}{9000 \text{ mg / mol}} \right) 5 \times 10^3 / \text{bucket} (1 \text{ barn } 10^{-24} \text{ cm}^2 / \text{barn})$$

$$R'_{\text{reaction}} = 167 / \text{bucket} @ 1 \text{ barn}$$